

PW12 | Digital-analogue position indicators

positive drive, technopolymer



CASE

Glass-fibre reinforced polyamide based (PA) technopolymer, black colour, matte finish.
Moulded-in spindle.

BEZEL

Technopolymer. Moulded over the window.

WINDOW

Transparent polyamide based (PA-T) technopolymer (practically unbreakable).

Resistant to solvents, oils, greases and other chemical agents (avoid contact with alcohol during cleaning operations).

DIAL

Natural matte anodised aluminium.

Clockwise or anti-clockwise graduation, black colour.

READING

Five-digits roller counter (four black rolls and one red roll) and one red pointer which turns on the graduated dial. The digit of the red roll shows the decimal values, while the pointer shows the hundredth.

The display indicates the displacement of the mechanism controlled by the spindle from the start position (0). One complete turn of the machine spindle corresponds to a turn of the handwheel/knob and consequently to a turn of the red pointer. A turn of the red pointer corresponds to a determinate reading on the counter (see "reading on the counter after one revolution of the red pointer" in the table).

IP PROTECTION

The ultrasonic welding of the window to the case guarantees the complete sealing with IP 65 protection class, see table IEC 529 (on page A-19).

FEATURES AND APPLICATIONS

Digital-analogue positive drive indicators are suitable with spindles in any position.

To choose the handwheel see the table "Handwheels/knobs - possible assembly with indicators" (on page 557).

SPECIAL EXECUTIONS ON REQUEST

- No pointer
- Plain dial
- Special dial with logo or customised graduations
- Special readings after one revolution.



ELESA Original design

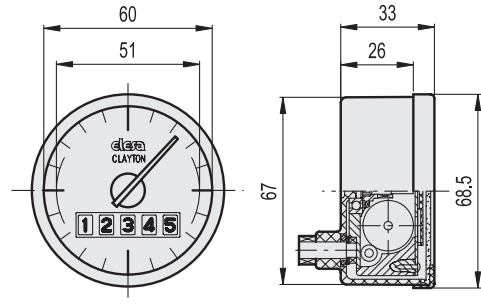

Example of description for ordering

PW12 - 00002 - D

Reading on the counter after one revolution of the red pointer

0 0 0 0 2	0 0 0 0 2	0 0 0 0 2	0 0 0 0 2
00002	0000.2	000.02	00.002
00005	0000.5	000.05	00.005
00008	0000.8	000.08	00.008
00010	0001.0	000.10	00.010
00012	0001.2	000.12	00.012
00012(5)	0001.2(5)	000.12(5)	00.012(5)
00015	0001.5	000.15	00.015
00020	0002.0	000.20	00.020
00025	0002.5	000.25	00.025
00030	0003.0	000.30	00.030
00035	0003.5	000.35	00.035
00040	0004.0	000.40	00.040
00050	0005.0	000.50	00.050

Graduation

Dial Graduation Number
20
50
40
100
60
100
100
40
50
60
70
80
100

Graduated dial resolution

Divide the reading of the counter for the number of graduations of the dial.

Example: 00002 /20=0.1

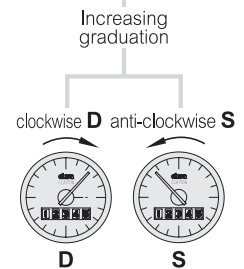

Position indicators